



Simple lift type three-dimensional parking garage

Simple parking equipment, simple action, safe and reliable, simple operation, while low cost. Chain-driven or hydraulic twin-cylinder, running quiet and smooth operation. The equipment used for enterprises and institutions, family housing and basement.

- With effective use of space, the space utilization rate is increased by several times.
- Steel structure, safe operation, long service life of equipment.
- With the introduction of a dozen of security devices, the equipment can run smoothly.



PJS (MINI)

PJS Mini Lifting Mechanical Parking Equipment (MINI)

Side view

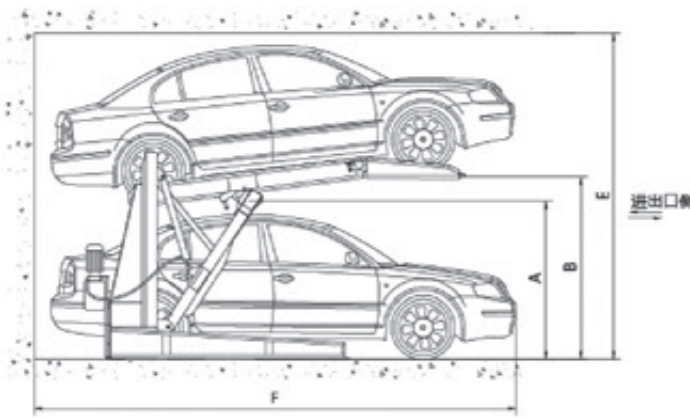

Construction layout

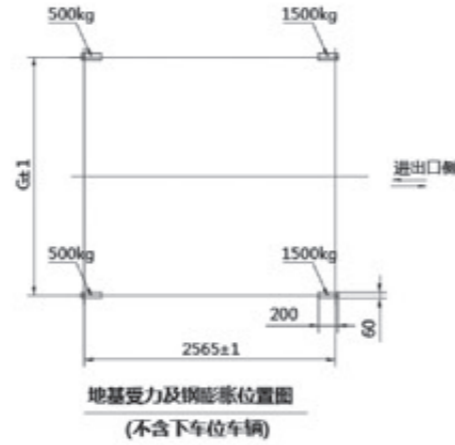

Top view

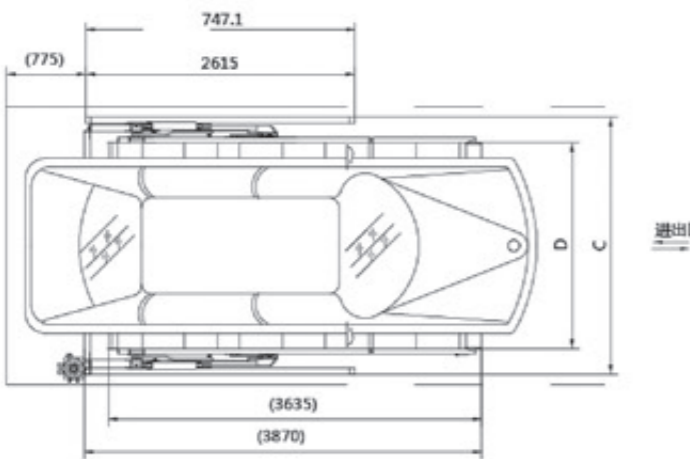

Fixed base diagram

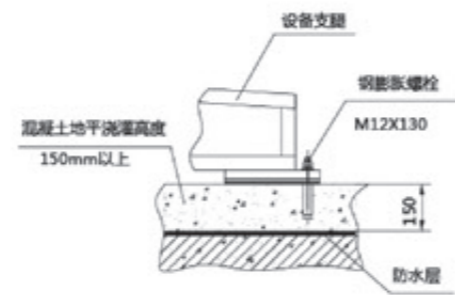

Specifications of vehicles					
Pattern	31A	31B	27A	27B	
Maximum car dimensions	Lenght	5000mm	4700mm	5000mm	4700mm
	Width	1850mm	1800mm	1850mm	1800mm
	With side mirror	1950mm	1900mm	1950mm	1900mm
	Height	1550mm	1450mm	1550mm	1450mm
	Weight	1700kg	1500kg	1700kg	1500kg

Technique parameter	
Operation method	Knob key switch
Control mode	Electrically controlled compression
Motor Power	1.5 kw
Power capacity	3 KVA
电源 Power	AC220V 50Hz
Rated speed	50s, 20s
Working pressure	16 MPa
Pressure Relief	20 MPa
Number of vehicles	2

尺寸规格 Specifications of size							
Type	A(Max)	B(Max)	C	D	E	F	G
31A	1700	2000	2495	2000	>3100	≥ 5100	2435
31B			2330	1835			2270
27A	1200	1800	2495	2000	2700-3100	>5400	2435
27B			2330	1835			2270

PJS

PJS Mini lifting Mechanical Parking Equipment (Four-pillar type)

Elevation

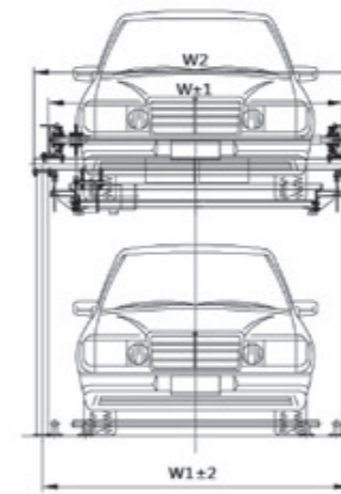

Side view

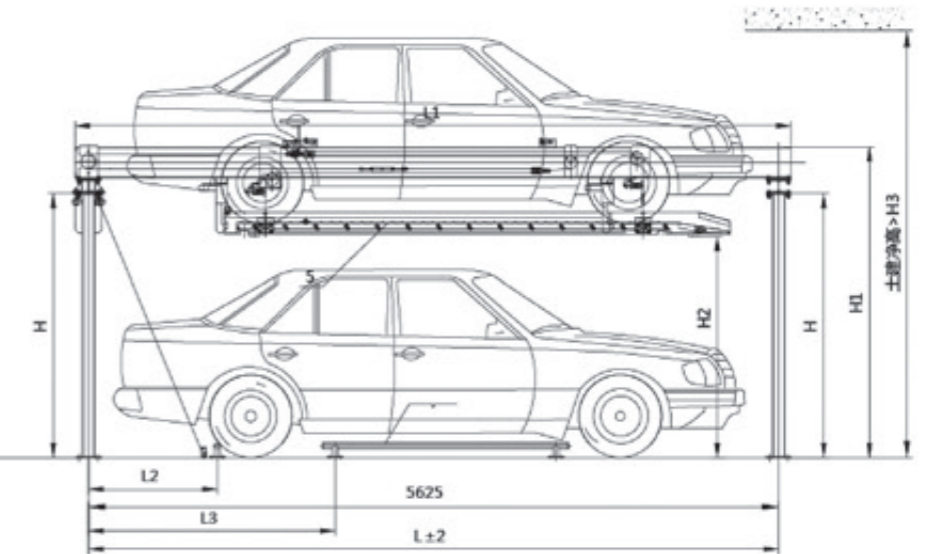

Distribution of frame

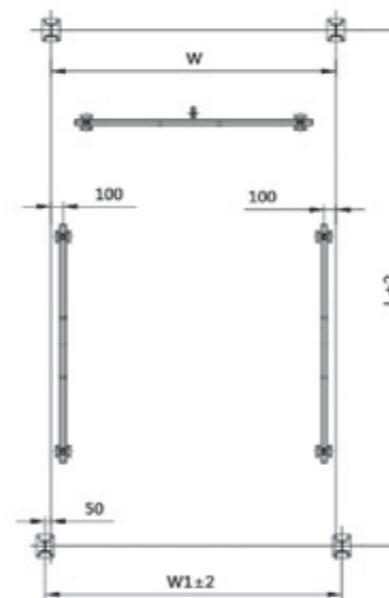

Width of vehicle	W	W1	W2	Note
1800	2300	2400	2540	2300
1850	2350	2450	2590	2350
1900	2400	2500	2640	2400
1950	2450	2550	2690	2450
2000	2500	2600	2740	2500
2050	2550	2650	2790	2550
2100	2600	2700	2840	2600

Length of vehicle	L	L1	L2	L3	Note
5200	5625	5835	1050	2010	
5100	5525	5735	1000	1960	
5000	5425	5635	950	1910	
4900	5325	5535	900	1860	
4800	5225	5435	850	1810	
4700	5125	5335	800	1760	

parameter	Technique parameter
Lift speed	4~5m/min
升 Lift motor power	2.2kW
Power	三相交流 380V 50Hz

High of vehicle		H	H1	H2	H3	Note
1550	1550	2152	2530	1800	3480	
1550	2050	2152	2530	1800	3980	
2050	1550	2502	2880	2150	3830	
2050	2050	2502	2880	2150	4330	



PPY

PPY PLANE SHIFTING MECHANICAL PARKING SYSTEM (VEHICLE PLATE TYPE)

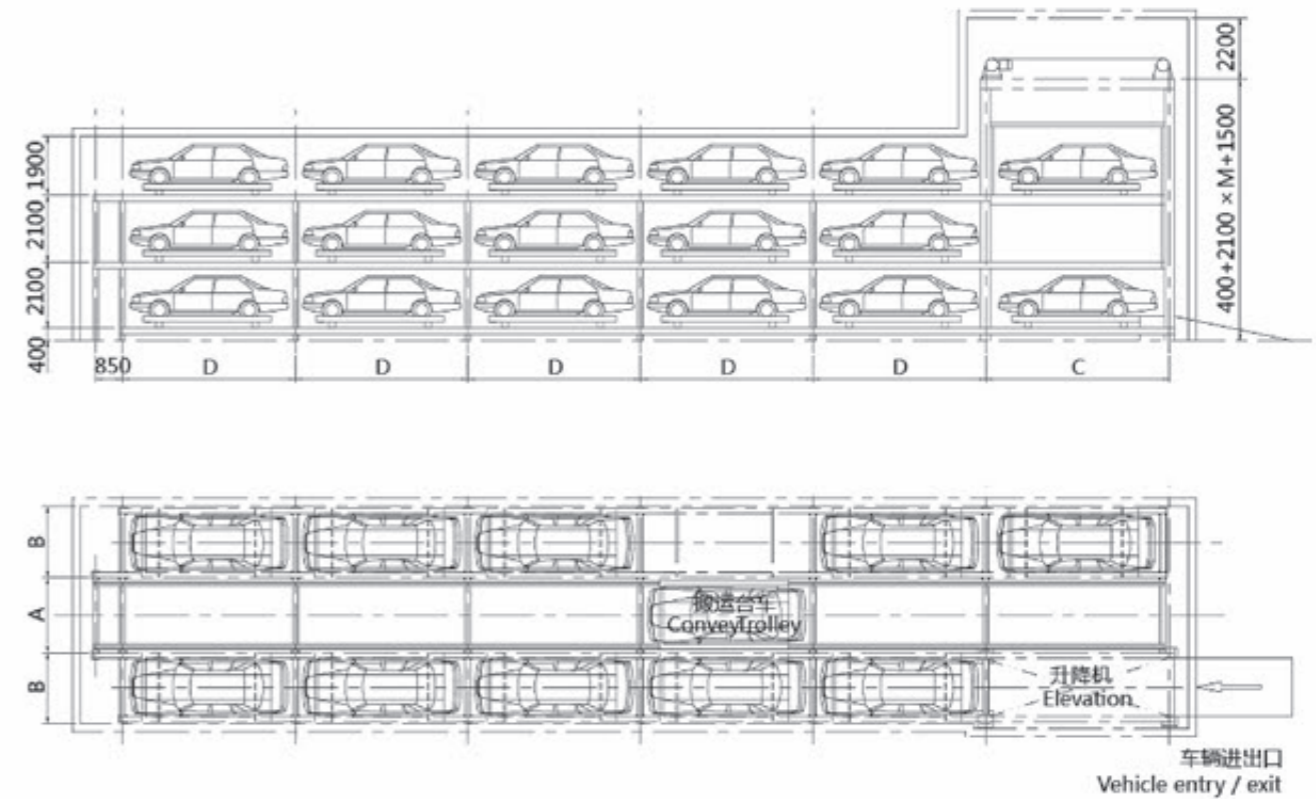

Plane Shifting Mechanical Parking System

- Without ramp way, it can save space; with large storage density, it can improve land utilization to the largest extent.
- With automatic vehicle parking and withdrawing system and quick control, single touch on button can complete vehicle parking or withdrawing.
- Equipped with safety protection, it is safe and reliable, and can avoid all kinds of accidents.

Technique parameter

project	type	T2
Dimensions and specifications of Vehicle	Total length	5200 mm
	Total Width(Does not contain side mirror)	1900 mm
	Total height	1550 mm
	Total weight	2200 kg
Lifting device		: 7.5kw 32m/min ()
Traversing device		: 0.75kw : 16m/min ()
Walking device		: 1.1kw*2 : 70m/min ()
Operation method		Touch screen / swing card
Power capacity		AC380V 50HZ 15KVA



Lift-sliding Mechanical Parking System

-
-
-
-
- Modular design, flexible installation, wide application;
- Quality steel structure, safe, reliable and durable;
- Fall-resistance, upper and lower limit, safe and reliable operation;
- High space utilization, doubled the parking numbers, suitable for communities and enlarging underground garage.

Technique parameter

项目 project	形式 type	PSH2	PSH3	PSH4	PSH5	PSH6
Total width		CXN () +150 CXN (mmbercifcolumns) +150	CXN 300 CXN (rxjmbrofocokiTins) +300	CXN+400	CXN+500	CXN+500
Park capacity		NX 2-1	NX 3-2	NX 4-3	NX 5-4	NX 6-5
Lift speed\Slide speed		4.0~5.0m/min\6.0 ~ 8.0m/min				
Lift reduce\slide reducer		2.2kw\0.2kw				
Power\Power capacity		380V 50Hz 4KVA-6KVA				
Drive mode		Note: two layers for the chain, three and above are cable type				
Operation method		Touch screen				